

TYPICAL LOT GRADING  
W/REAR DRAINAGE  
NTS

NOTE:  
ALL LOTS WITH THE EXCEPTION OF  
LOTS 19 & 20 BLOCK 2

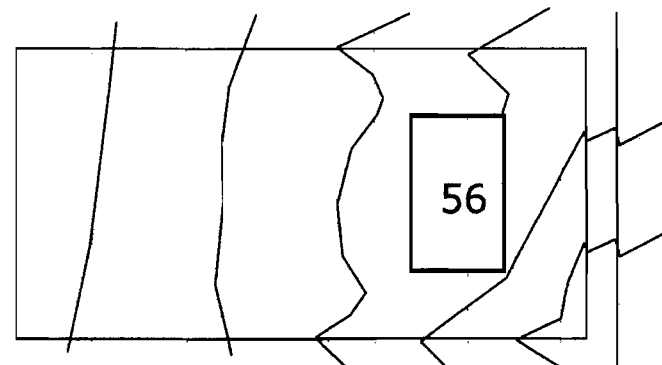

LOT 19 & 20 GRADING  
W/STREET DRAINAGE  
NTS

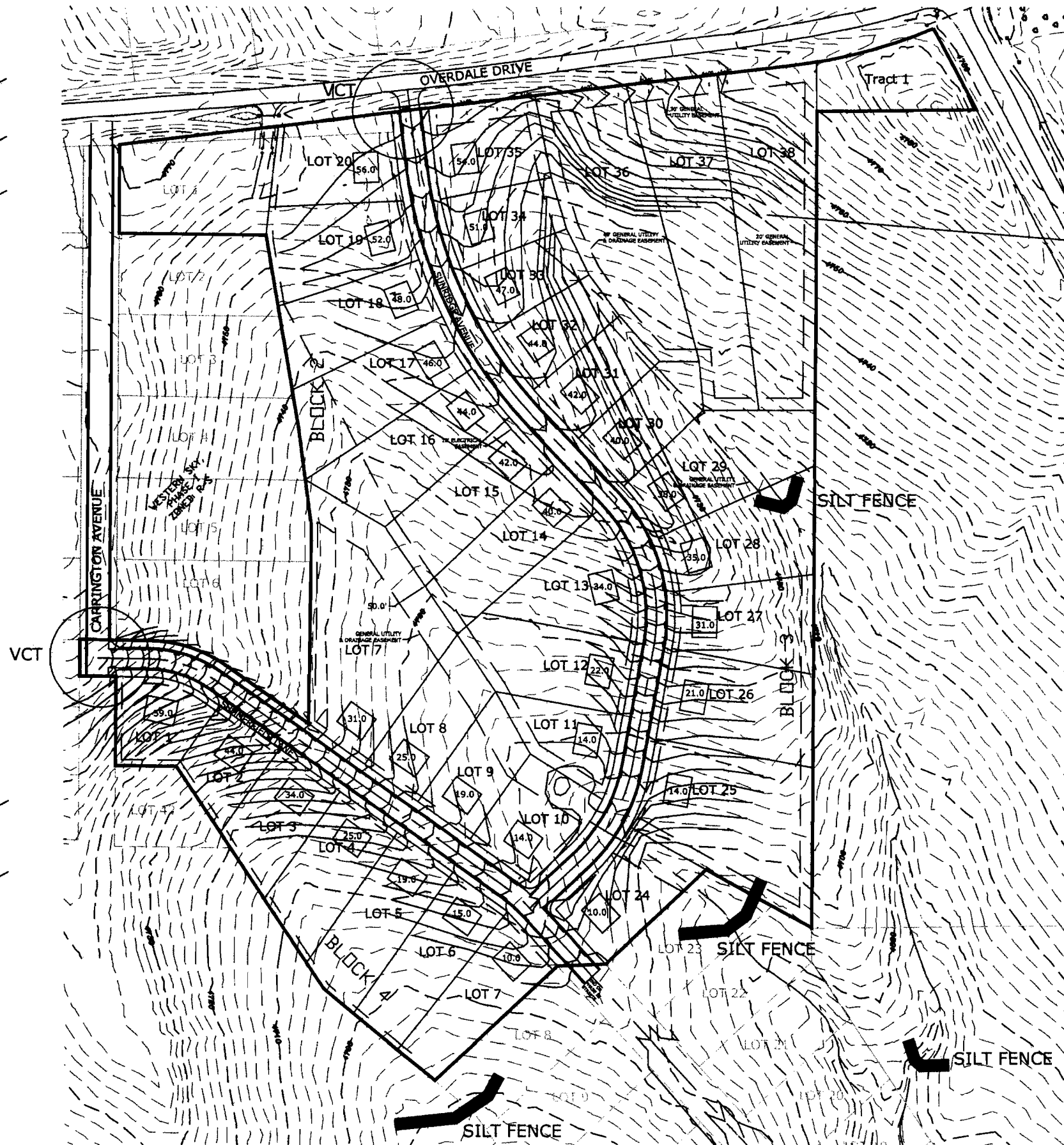

NOTE:  
FILL 4:1 FROM ELEVATION 4740 TO 4750 THEN 6:1

NOTES:  
-TOP OF FOUNDATION WALL ELEVATIONS ARE CONCEPTUAL ONLY.  
OWNER HAS LEEWAY IN THE DESIGN OF STRUCTURES.  
-ADD SILT FENCE AND STRAW BALES AS NEEDED.

56 TOP OF FOUNDATION WALL ELEVATION



GRADING

WESTERN SKY, PHASE III  
Gillette, WY

Prepared for:  
Western Skyline  
Development, LLC  
PO BOX 92  
Gillette, WY 82717

Prepared by:  
DOYLE LAND SURVEYING  
405 W. Boxelder Road, Ste.C-8  
Gillette, WY 82718  
PH: (307)666-2410  
ROADRUNNER CNSTRUCTION

REVISED 10/13/06  
REVISED 9/22/06

Date of Preparation: AUGUST, 2006 SHT 3 OF 19